

Name of the Student: \_\_\_\_\_

Max. Marks : 24 Marks

Time : 24 Minutes

Mark Schemes

**Q1.**

(a) general procedure

- collect water for a measured time;
- **divide** measured / calculated volume by time to determine rate <sub>1✓</sub>  
*static volume should be measured **after timing**, eg  
 reject 'measure time to fill cylinder' or <sub>1✓</sub> = 0  
 accept 'find V for different t, plot V against t,  
 gradient = Q' but not if by continuous flow method*

1

names 2 suitable instruments <sub>2✓</sub>

*for time use stopwatch or stopclock;  
 treat as neutral: 'timer' or 'light gate / data logger'  
 for volume use measuring cylinder / graduated beaker;  
 treat as neutral: 'measuring beaker' / 'burette'  
 OR*

*for mass use balance; use of  $V = \frac{m}{\rho}$  (any subject)  
 condone 'volume of 1 g is 1 cm<sup>3</sup>';  
 reject 'weigh'/'weighed'*

1

method to reduce uncertainty in volume <sub>3✓</sub>

*read water level at bottom of the meniscus (or write or allow sketch);  
 don't penalise further use of 'beaker' treat as neutral: 'dry cylinder  
 before use'*

OR

*procedure to avoid systematic error in determining mass, eg tare /  
 reset / zero the balance with empty beaker on pan / find mass of  
 beaker empty and subtract from mass of beaker plus water;  
 don't penalise further use of 'weigh' / 'scales' allow 'use balance on a  
horizontal surface'*

method to reduce uncertainty in time <sub>4✓</sub>

*✓ ensure stopwatch is zeroed / reset before use*

added detail <sub>5✓ 6✓ 7✓</sub>

*collect large(r) volume / for long(er) time /  $\geq 60$  s <sub>5✓</sub>*

this reduces percentage / fractional uncertainty  $\checkmark$   
read at eye level or wtte, to reduce parallax  $\checkmark$

MAX 2

- (b) sensible mark identifying second box indicating ( $N\ m^{-2}\ s$ ) only  
**auto marked question**

1

- (c) 19.8% (from  $4 \times 2.9\% + 1.8\% + 6.4\%$ ) earns both marks  $\checkmark\checkmark$   
don't insist on seeing '%' unless 0.198 etc  
allow final answer rounded to 20%  
allow 1 mark for 0.198 or 0.20 but reject 1 sf 0.2  
for incorrect answer the following can earn one mark:  
(percentage uncertainty in  $d$ )  $4 \times 2.9\% / 11.6\% / 12\%$  seen in working  
but wrong final answer  
OR missing  $\times 4$  eg  $2.9\% + 1.8\% + 6.4\% = 11(.1)\%$   
OR incorrect multiplier applied to 2.9 eg  $2 \times 2.9\%$   
OR with  $\times 4$  applied wrongly eg  
 $2.9 + (1.8 \times 4) + 6.4 = 16.5\%$  or  $17\%$  /  
 $2.9 + 1.8 + (6.4 \times 4) = 30(.3)\%$

2

- (d) appropriate use (ie close to and parallel with the vertical side of the tube, but not necessarily in contact with the tube) of:

a metre ruler made vertical using a set-square in contact with the bench / floor / (flat) surface

OR

a plumb line / weight on vertical string (reject 'pendulum')

OR

a spirit level  $\checkmark$

*the mark can be awarded for a convincing sketch, eg use of a very large set square without ruler*

*accept 'tri-square' for set square*

*the only acceptable horizontal reference is the bench: don't allow use of horizontal T, eg set square placed on T even if sketch looks convincing*

*no credit for attempt to show graduations on tube are horizontal / use of 'protractor' for set-square / 'each side of meniscus at same level' / use of clamp stand rod or wall as vertical reference*

1

- (e) attempted use of  $y = y_0 e^{-\lambda t}$  with substitution of values of  $y$ ,  $y_0$  and  $\Delta t$  obtained **directly** from **Figure 4** / plausible values obtained from **Figure 7**

OR

tangent drawn on **Figure 4** to find  $\frac{dy}{dt}$  ;

use of  $\frac{dy}{y} = (-)\lambda \times y^*$  and  $y^*$  is where tangent meets the curve  $_1\checkmark$

valid calculation **seen** leading to a result for  $\lambda$  that rounds to 3 sf in range  $4.45$  to  $4.55 \times 10^{-3} \text{ (s}^{-1}\text{)}$ ;

award if seen in body of answer  $_2\checkmark$

for  $_1\checkmark$  do not penalise  $y / y_0$  interchanged, read off

errors, manipulation errors /  $\Delta t = t / t_0 / \frac{t}{t_0}$  or use of incorrect symbols  
eg A, N for y;

no ecf for  $_2\checkmark$

allow use of **Figure 7**

$y_0 = 60.0 \text{ cm}$ ,  $y = 52.2 \text{ cm}$ ;  $\Delta t = 60 - 29 = 31 \text{ s}$

$52.2 = 60 e^{-31\lambda}$ ;  $\therefore \lambda = 4.49 \times 10^{-3} \text{ s}^{-1}$

if the intermediate step is seen, eg

$$\lambda = \frac{1}{\Delta t} \times \ln\left(\frac{y_0}{y}\right) = \frac{1}{31} \times \ln\left(\frac{60}{52.2}\right)$$

accept 'log' for 'ln'

no credit allowed for reverse-working method in a 'Show that' problem

no credit for assuming straight line and  $y = mx + c$ , measuring the gradient then by determining the

equation of the line or by using  $m = \frac{y_2 - y_1}{t_2 - t_1}$

determines the half life; finds  $\lambda$  from  $\frac{\ln 2}{\text{half life}}$   
no credit for common error  $\lambda = \text{gradient} \times 2$

for  $_2\checkmark$  look for any answer in the body that deserves credit (for a 'Show that' we can overlook truncation in the value given on the answer line)

variation on use of use of  $y = y_0 e^{-\lambda \Delta t}$  for  $_1\checkmark$ :

$\lambda$  can be found if points  $t_1, y_1$  and  $t_2, y_2$  are used and the values substituted into

$$\frac{y_1}{e^{-\lambda t_1}} = \frac{y_2}{e^{-\lambda t_2}} ;$$

$$\lambda = \frac{1}{\Delta t} \times \ln\left(\frac{y_0}{y}\right)$$

if this approach is used substitute the data into  $\lambda = \frac{1}{\Delta t} \times \ln\left(\frac{y_0}{y}\right)$  to confirm that the result for  $\lambda$  is correct before awarding  $_2\checkmark$

1  
1

(f) use of  $T_{1/2} = \frac{\ln 2}{\lambda}$  OR  $\frac{\ln 0.5}{-\lambda}$  with substitution of **recognisable**  $\lambda$ ;

evaluated to  $\geq 2$  sf in range  $140 \text{ s}$  to  $170 \text{ s}$   $\checkmark$

calculation can have any subject;

accept use of 2 sf  $\lambda = 4.5 \times 10^{-3}$  usually leading to 154 but allow correctly truncated to 150 or  $1.5 \times 10^2$

1

- (g) (mostly) continuous line drawn on **Figure 7**;  
 below dashed line and with negative gradient between  $t = 0$  and  $t = 120$ ;  
 do not penalise linear line or shaky / thick / hairy line or slight  
 discontinuities; accept  $\approx$  horizontal after 100 s  $_1 \checkmark$

line passes through:

$t/s$	$y/cm$	
	min	max
0	33	35

AND through EITHER of

$t/s$	$y/cm$	
	min	max
60	24	28
120	17	23

$_2 \checkmark$

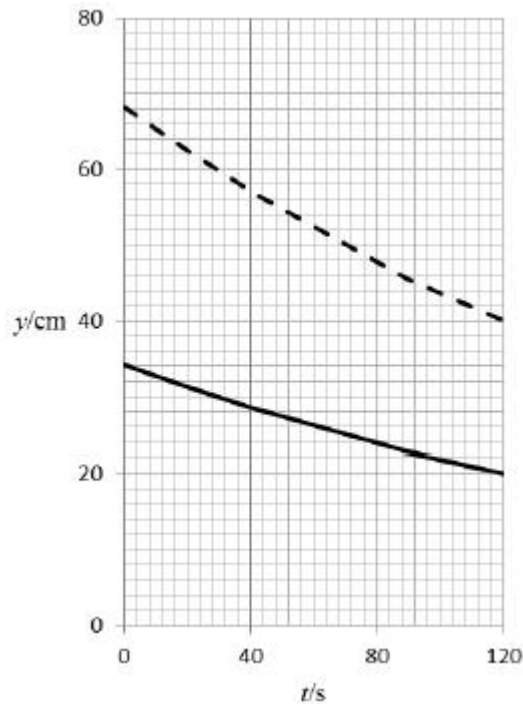

2

[13]

**Q2.**

- (a) to reduce the impact of systematic error: tare [zero] the callipers before use  
**OR**  
 take reading with callipers fully closed (at some stage) and subtract from readings  $_1 \checkmark$
- to reduce the impact of random error: take measurement several times for different diameters/directions and calculate mean  
**OR**  
 take measurement several times for different diameters to check for anomalies  $_2 \checkmark$

2

- (b) use of inside jaws on callipers required: must have a clear drawing with inside jaws in contact internal diameter, ✓

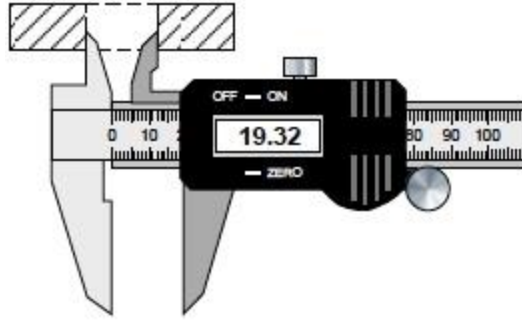

A **sectional** view of the magnet must be given  
Jaws must be inside cavity (as here)

1

- (c) Determines a cross-sectional area: (larger A=) 2.82

$\times 10^{-3}$  or (smaller area =)  $2.932 \times 10^{-4}$

OR

states that the cross sectional area from  $\Delta$

$$A = \left( \frac{\pi D^2}{4} - \frac{\pi d^2}{4} \right)$$

OR

Calculates one volume correctly ✓

Allow POT error ✓ and ✓

Where  $r$  is used must have an additional statement on how  $r$  relates to  $D$  (in the case where there is no correct substitution and no correct answer)

substitution of  $D = 59.90$ ,  $d = 19.32$  and  $t = 12.09$  into

$$V = \left( \frac{\pi D^2}{4} - \frac{\pi d^2}{4} \right) \times t$$

OR

$V = \text{their } \Delta A \times 12.09$

OR

Correctly finds difference in **their** volumes ✓

Or equivalent

Correct substitution into

$$V = \left( \frac{\pi D^2}{4} - \frac{\pi d^2}{4} \right) \times t$$

receives the first two marks (allow POT)

Expect values:

$$V_D = 3.41 \times 10^{-5} \text{ (m}^3\text{)}$$

$$V_d = 3.54 \times 10^{-6} \text{ (m}^3\text{)}$$

$$3.1 \times 10^{-5} / 3.05 \times 10^{-5} / 3.053 \times 10^{-5} \text{ (m}^3\text{)}_3 \checkmark$$

*no limit on maximum sf*

*Correct answer scores 3*

*Allow 3rd sf round error where*

*answer rounds to  $3.1 \times 10^{-5}$*

*when correct method seen*

3

(d) **Procedure:**

**MAX 2**

Take more measurement(s) of  $h$  for additional / different masses (of clay)  $\checkmark$

*More than one added mass, allow varies amount of clay*

Convert (total) mass into weight (and equal to the repulsive force of magnet **A** on magnet **B**)  $\checkmark$

Describe method to measure  $h$  using ruler or set square  $\checkmark$

*(in this case determination of  $k$  must be consistent with graph)*

**Analysis:**

Plot a graph of  $F$  against  $1/h^3$   $\checkmark$

*Condone  $1/h^3$  against  $F$  or equivalent*

Should be a straight line of best fit  $\checkmark$

*This mark can be awarded if seen by drawing of straight line with positive gradient on sketch of graph*

**Determination of  $k$ :**

**MAX 1**

Measure gradient and set equal to  $k$   $\checkmark$

*Allow one mark for plot of  $F$  against  $h^3$  and statement that area under graph is  $k$ . Mark **Procedure** as scheme*

Substitute (total) weight into formula and rearrange to find  $k$   $\checkmark$

*Must be consistent with graph*

5

[11]