

Name of the Student: \_\_\_\_\_

Max. Marks : 21 Marks

Time : 21 Minutes

**Q1.**

In a discharge tube a high potential difference is applied across hydrogen gas contained in the tube. This causes the hydrogen gas to emit light that can be used to produce the visible line spectrum shown in **Figure 1**.

**Figure 1**

The visible line spectrum in **Figure 1** has been used to predict some of the electron energy levels in a hydrogen atom.

The energy levels predicted from the visible line spectrum are those between 0 and  $-3.40$  eV in the energy level diagram.

Some of the predicted energy levels are shown in **Figure 2**.

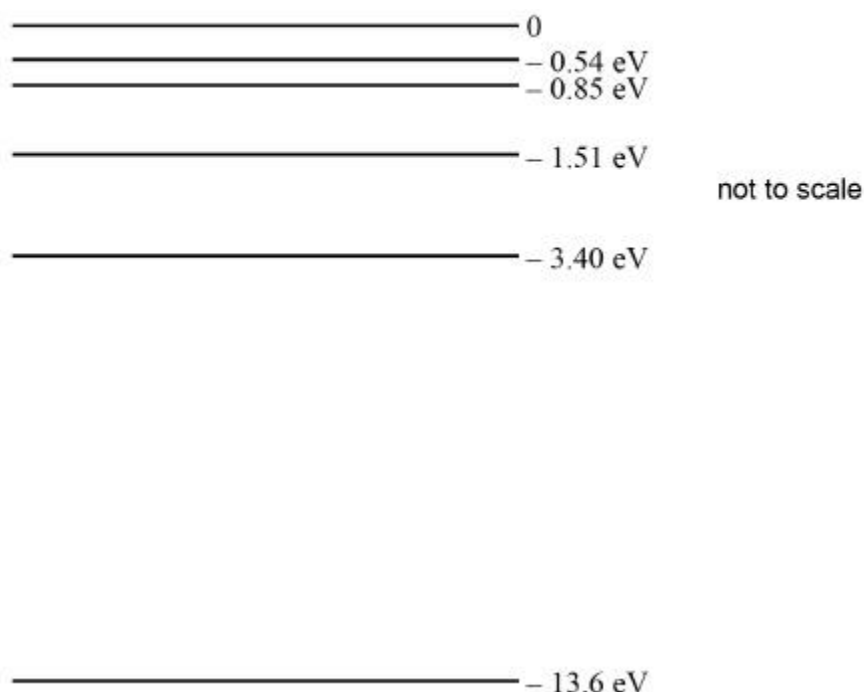
**Figure 2**

- (a) Calculate the energy, in eV, of a photon of light that has the lowest frequency in the visible hydrogen spectrum shown in **Figure 1**.

energy of photon = \_\_\_\_\_ eV

(3)

- (b) Identify the state of an electron in the energy level labelled 0.

---

---

(1)

- (c) Identify the state of an electron that is in the energy level labelled  $-13.6$  eV.

---

---

---

(1)

- (d) Explain why the energy levels are negative.

---

---

---

(1)

- (e) Discuss how the discharge tube is made to emit electromagnetic radiation of specific frequencies.

In your answer you should:

- explain why there must be a high potential difference across the tube
- discuss how the energy level diagram in **Figure 2** predicts the spectrum shown in **Figure 1**
- show how one of the wavelengths of light is related to two of the energy levels in the energy level diagram.

---

---

---

---

---

---

---

---

---



---



---



---



---

(6)  
(Total 12 marks)

**Q2.**

**Figure 1** represents an ion propulsion unit used on a spacecraft launched in 1998.

Atoms of xenon-131 ( ${}^{131}_{54}\text{Xe}$ ) were injected from a storage tank into a chamber where they became ionised due to collisions with electrons.

A negatively charged grid attracted the xenon ions, accelerating them out of the back of the ion propulsion unit and causing the spacecraft to be propelled forward.

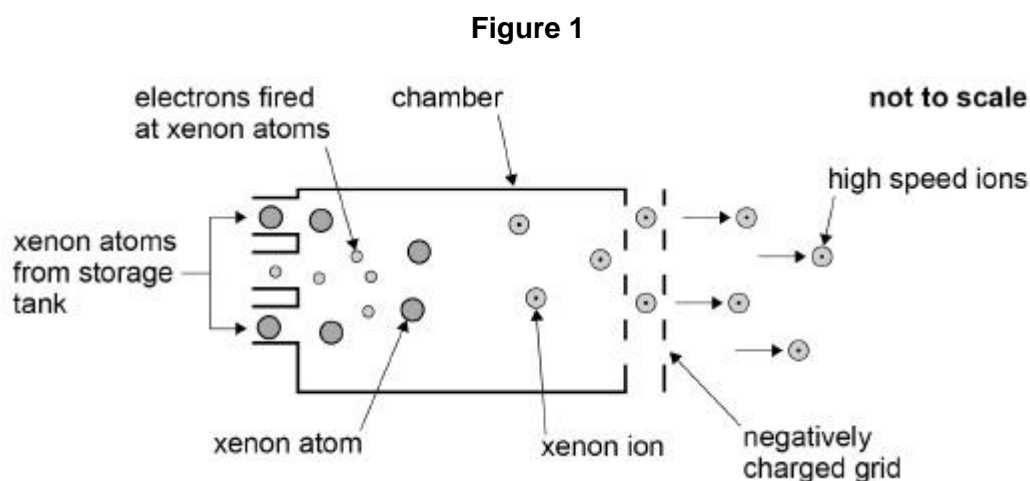

- (a) The mass of a  $\text{Xe}^+$  ion is  $2.18 \times 10^{-25}$  kg.  
Calculate the specific charge of a  $\text{Xe}^+$  ion.  
Give an appropriate unit for your answer.

specific charge = \_\_\_\_\_ unit \_\_\_\_\_

(2)

- (b) The storage tank contained 79 kg of xenon. When the ion propulsion unit was switched on it had an average power output of 2.1 kW.

Each xenon ion gained 1300 eV of energy as it was accelerated and ejected out of the



