

Name of the Student: _____

Max. Marks : 22 Marks

Time : 22 Minutes

Q1.

The International Space Station (ISS) orbits the Earth with a constant speed v . The orbit is circular and of radius r .

(i) The ISS completes one orbit in 92 minutes.

Calculate the centripetal acceleration of the ISS.

$r = 6800 \text{ km}$

(3)

.....
.....
.....
.....
.....

Centripetal acceleration =

(ii) Astronauts in the ISS are often described as being "weightless".

Discuss whether the astronauts are "weightless" when they are orbiting the Earth in the ISS.

(4)

.....
.....
.....
.....
.....
.....
.....
.....
.....

(Total for question = 7 marks)

Q2.

A student rows across a river heading from point A. Her boat is headed in a direction at right angles to the bank and she rows through the water at a constant speed of 1.5 m s^{-1} . The river flows with a current of 1.1 m s^{-1} .

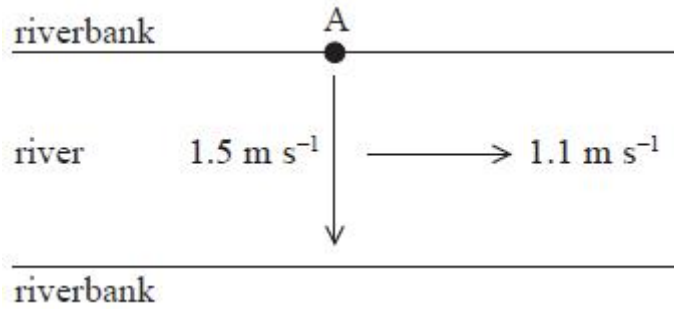

(a) Calculate the velocity of her boat relative to the riverbank.

(4)

.....

.....

.....

.....

.....

.....

Magnitude of velocity =

Angle of velocity to the riverbank =

(b) Another student also rows through the water at a constant speed of 1.5 m s^{-1} and heads their boat in a direction at 65° to the riverbank.

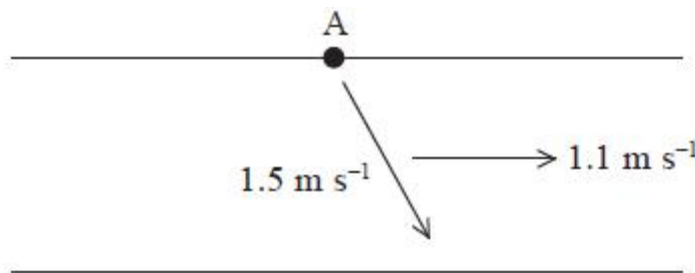

On the grid below draw a scaled vector diagram to determine the velocity of the boat.

(3)

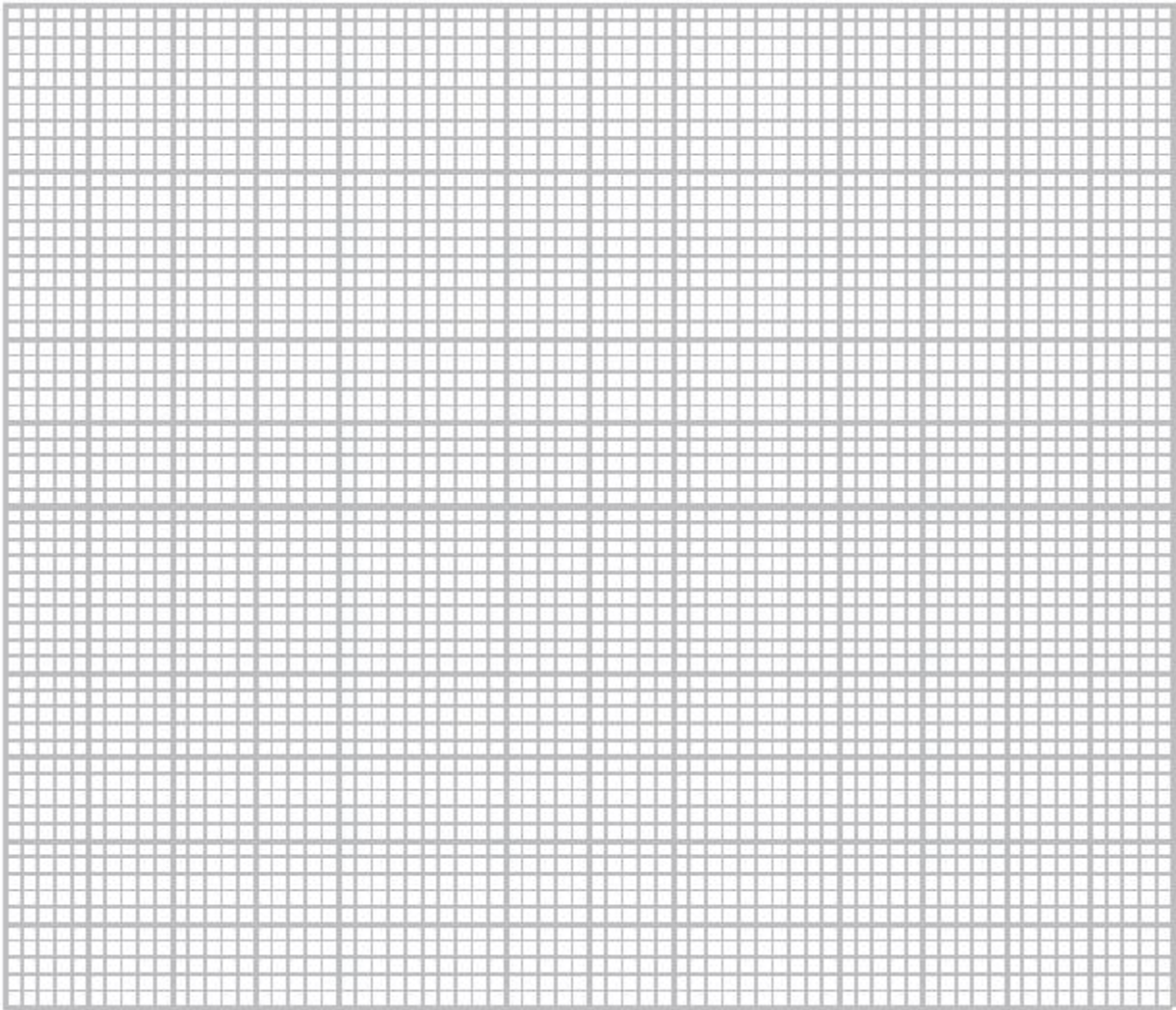

Magnitude of velocity =

Angle of velocity to the riverbank =

(Total for question = 7 marks)

Q3.

A coil of wire is placed around the lower end of an iron rod. The coil is supplied with an alternating current. A thick aluminium ring is placed around the iron rod above the coil. The coil remains in the position shown.

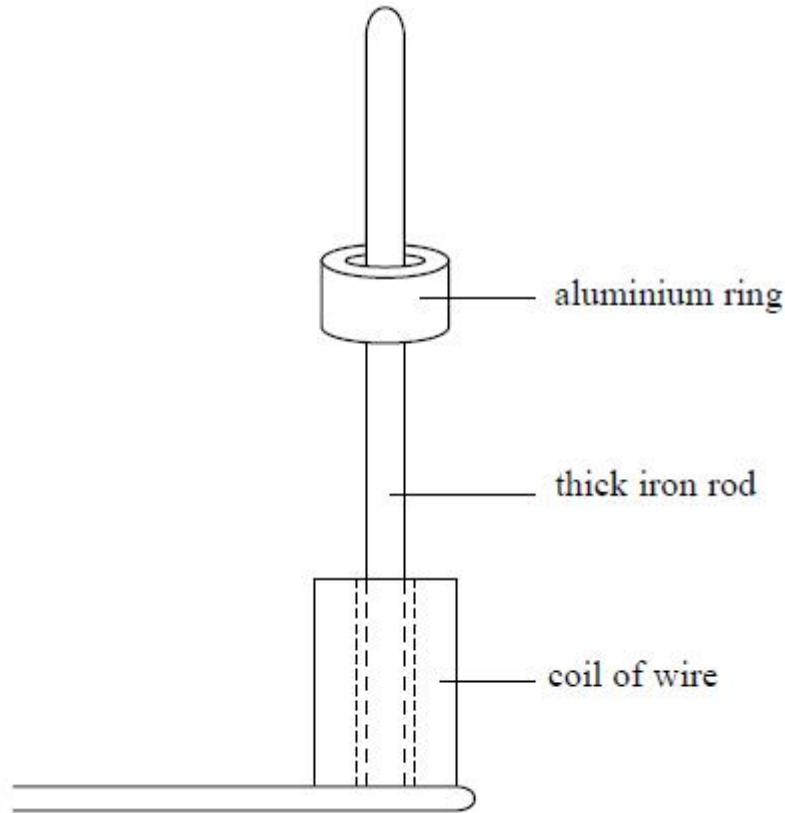

The current is switched off and the aluminium ring comes to rest on top of the coil. The supply to the coil is changed and a direct current (dc) is switched on. An upwards force F acts on the ring for 0.05 s accelerating it to a final speed, v . The ring then moves freely through a height of 30 cm.

- Mean diameter of ring = 4.8 cm
- Mass of ring = 0.019 kg
- Magnetic field strength = 0.032 T

(i) Use conservation of energy to calculate the speed v of the ring after 0.05 s.

(2)

.....
.....
.....
.....

$v =$

(ii) Use the idea of impulse to calculate the magnitude of the mean force F acting on the ring and hence the mean current I in the ring.

(6)

.....
.....
.....

.....
.....
.....
.....
.....

$F =$

$I =$

(Total for question = 8 marks)