

Practice Question Set For A-Level
Subject : Physics
Paper-1 Topic : 3_ElectricCircuits

Name of the Student: _____

Max. Marks : 20 Marks

Time : 20 Minutes

Mark Schemes

Q1.

Question Number	Answer	Mark
	<p>The only correct answer is D ammeter reading decreases and voltmeter decreases <i>A is not correct because the overall resistance of the circuit is increasing, so the current must decrease.</i> <i>B is not correct because the overall resistance of the circuit is increasing, so the current must decrease.</i> <i>C is not correct because the current decreases, but as $V=IR$ this would not increase the voltmeter reading</i></p>	1

Q2.

Question Number	Acceptable answers	Additional guidance	Mark
	<p>The only correct answer is D <i>A is not correct because as it is $2A + 1A$</i> <i>B is not correct because $2A + 2A$</i> <i>C is not correct because $2A + 3A$</i></p>	6 A	1

Q3.

Question Number	Answer	Mark
	B	1

Q4.

Question Number	Answer	Mark
	B	1

Q5.

Question Number	Answer	Mark
	D	1

Q6.

Question Number	Answer	Mark
	D	1

Q7.

Question Number	Answer	Mark
	B	1

Q8.

Question Number	Answer	Mark
	D 1080 C	1
	Incorrect Answers: A – current divided by time, with the time in seconds B – current divided by time, with the time in minutes C – correct formula of current \times time but the time is in minutes and not seconds	

Q9.

Question Number	Answer	Mark
	B filament bulb	1
	Incorrect Answers: A – this is not the graph for a diode C – this is not the graph for an ohmic resistor D – this is not the graph for a thermistor	

Q10.

Question Number	Answer	Mark
	A dark and cold	1
	Incorrect Answers: B – correct description for LDR but incorrect for thermistor C – incorrect description for LDR but correct for thermistor D – incorrect description for LDR and incorrect for thermistor	

Q11.

Question Number	Answer	Mark
	D Step 4	1
	Incorrect Answers: A – this step uses the conservation of energy B – this step is just a statement of Ohm's law C – this step uses the conservation of energy	

Q12.

Question Number	Acceptable answers	Additional guidance	Mark
	C		1

Q13.

Question Number	Acceptable answers	Additional guidance	Mark
	The only correct answer is A <i>B is not correct because V decreases as I decreases</i> <i>C is not correct because I decreases as R increases</i> <i>D is not correct because I decreases as R increases</i>	decreases decreases	1

Q14.

Question Number	Acceptable answers	Additional guidance	Mark
	A The p.d. across the resistor added to the p.d. across the thermistor must equal 6 V. This occurs when the current is 0.5 A.	0.5	1
	B assumes all the p.d. is across the thermistor C assumes that resistor and thermistor connected in parallel D assumes that the p.d. across the resistor and thermistor is more than 6 V		

Q15.

Question Number	Answer	Mark
	B thermistor graph	1
	Incorrect Answers: A – ohmic conductor graph C – filament lamp graph D – diode graph	

Q16.

Question Number	Answer	Mark
	B	1

Q17.

Question Number	Acceptable answers	Additional guidance	Mark
	C	joule per coulomb.	1
	Incorrect Answers: A is reciprocal of volt B is definition of amp D is definition of watt		

Q18.

Question number	Acceptable answers	Additional guidance	Mark
	D		1

Q19.

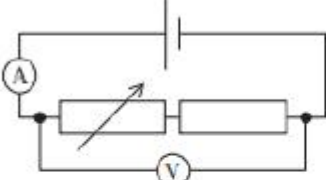
Question Number	Answer	Mark
	<p>A</p> 	1
	<p>Incorrect Answers:</p> <p>B – the ammeter would measure the current in the cell, but the voltmeter would not be measuring the p.d. across the cell</p> <p>C – the voltmeter would measure the p.d. across the cell but the ammeter would not be measuring the current in the cell</p> <p>D – the voltmeter would measure the p.d. across the cell but the ammeter would not be measuring the current in the cell</p>	

Q20.

Question Number	Acceptable answers	Additional guidance	Mark
	<p>The only correct answer is D</p> <p>A is not correct as current through $60\ \Omega$ is 4 A so $I = 6\ \text{A}$</p> <p>B is not correct as current through $60\ \Omega$ is 4 A so $I = 6\ \text{A}$</p> <p>C is not correct as current through $60\ \Omega$ is 4 A so $I = 6\ \text{A}$</p>		1