

Student: _____

Max. Marks : 17 Marks

Time : 17 Minutes

Q1.

A student is investigating electromagnetic induction using a U-shaped magnet. The magnetic flux density between the poles of the magnet is 74 mT. The magnetic field outside the region of the poles is negligible. She places a stiff copper wire between the poles of the magnet as shown in the diagram. The wire is connected to an ammeter of resistance 0.25Ω

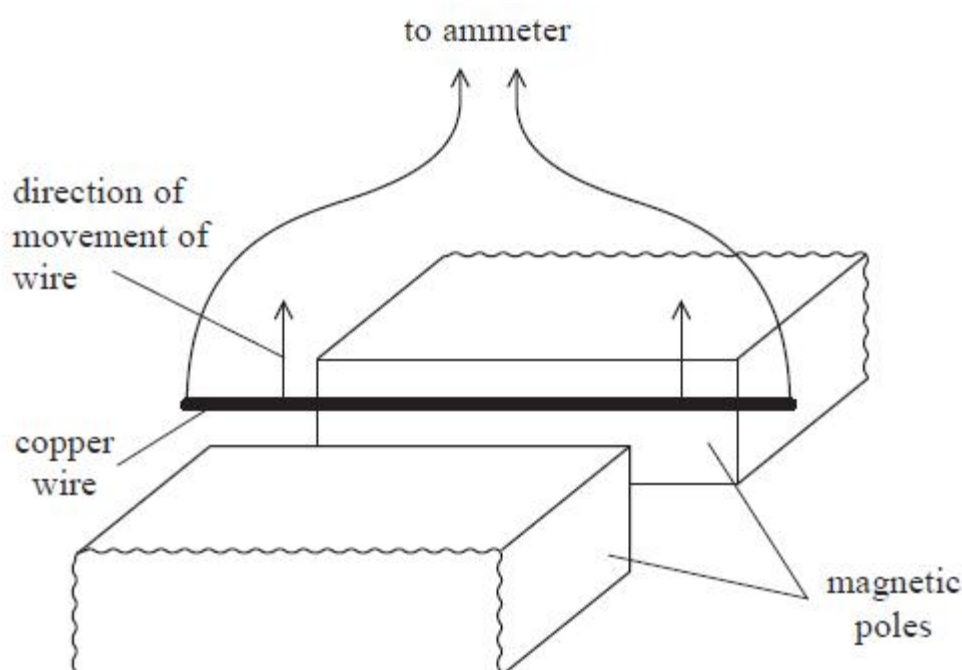

(a) The rectangular poles measure $6.0 \text{ cm} \times 2.4 \text{ cm}$.

Show that the magnetic flux between the poles of the magnet is about $1 \times 10^{-4} \text{ Wb}$.

(3)

.....
.....
.....
.....
.....
.....

(b) The student holds the wire as shown in the diagram and moves it vertically upwards at a constant speed of 1.2 m s^{-1}

Calculate the e.m.f. induced in the wire when it is moving.

Induced e.m.f. =

(c) According to Lenz's law, a force will act on the wire to oppose the motion of the wire.

Calculate the magnitude of the force that opposes the motion and comment on this value.

(4)

Magnitude of force =

Comment

(Total for question = 10 marks)

Q2.

An alpha particle and a beta particle both move into the same uniform magnetic field which is perpendicular to their direction of motion. The beta particle travels at 15 times the speed of the alpha particle.

The ratio of the force on the beta particle to the force on the alpha particle is

- A** 3.7
- B** 7.5
- C** 30
- D** 60

(Total for question = 1 mark)

Q3.

A mass-spectrometer is an instrument that is used to measure the masses of molecules. Molecules of a gas are ionised and travel through a vacuum in a narrow tube. The ions enter a region of uniform magnetic flux density B where they are deflected in a semicircular path as shown.

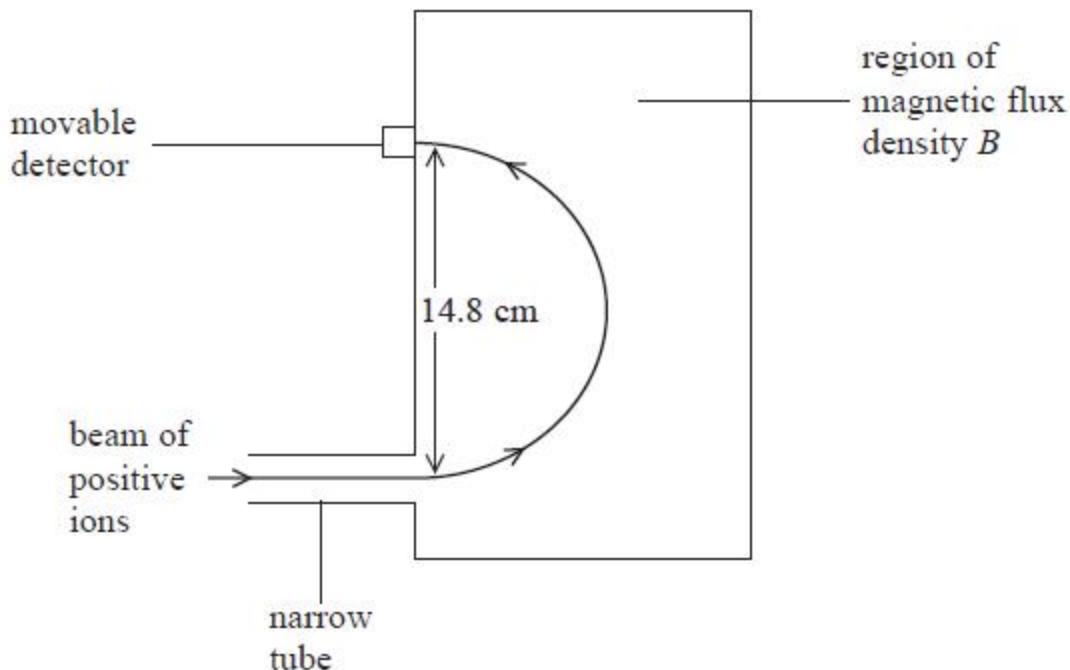

(a) State why it is necessary for the molecules to be ionised.

(1)

.....
.....

(b) State the direction of the magnetic field.

(1)

.....
.....
.....

(c) The ions have a charge of $+e$ and a speed of $1.20 \times 10^5 \text{ m s}^{-1}$. When B has a value of 0.673 T , the ions are detected at a point where the diameter of the arc is 14.8 cm .

Calculate the mass of an ion.

(3)

.....
.....
.....
.....
.....
.....

Mass of an ion =

(d) Ions with a smaller mass but the same charge and speed are also present in the beam.
On the diagram sketch the path of these ions.

(1)

(Total for question = 6 marks)