

Name of the Student: \_\_\_\_\_

Max. Marks : 25 Marks

Time : 25 Minutes

**Q1.**

**Diagram 1** shows a hairdryer.

**Diagram 2** shows how the heaters and fan of the hairdryer are connected to a 3-pin plug. The hairdryer does not have an earth wire.

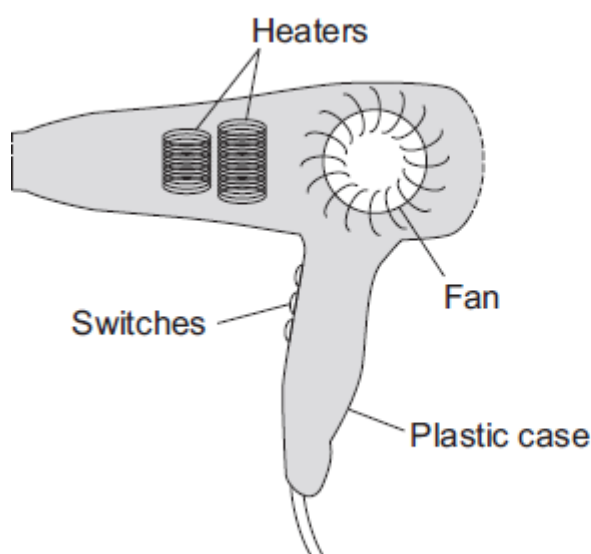

**Diagram 1**

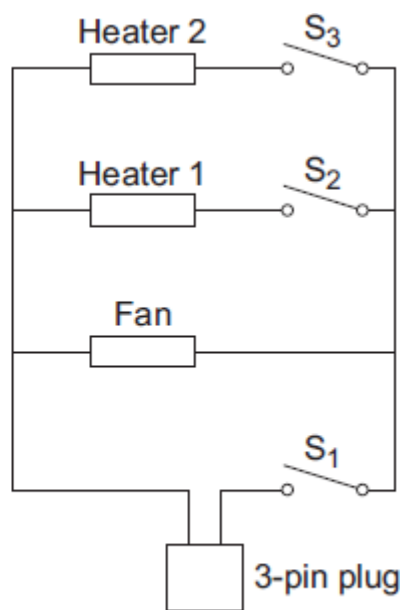

**Diagram 2**

(a) What colour is the insulation around the wire connected to the live pin inside the plug?

\_\_\_\_\_ (1)

(b) Why does the hairdryer **not** need an earth wire?

\_\_\_\_\_  
 \_\_\_\_\_ (1)

(c) All the switches are shown in the OFF position.

(i) Which switch or switches have to be ON to make:

(1) only the fan work; \_\_\_\_\_

(2) heater 2 work? \_\_\_\_\_

(2)

- (ii) The heaters can only be switched on when the fan is also switched on.

Explain why.

---

---

---

---

---

(2)

- (d) The table shows the current drawn from the 230 volt mains electricity supply when different parts of the hairdryer are switched on.

	Current in amps
Fan only	1.0
Fan and heater 1	4.4
Fan and both heaters	6.5

Calculate the maximum power of the hairdryer.

Show clearly how you work out your answer and give the unit.

---

---

Maximum power = \_\_\_\_\_

(3)

(Total 9 marks)

## Q2.

The picture shows a new washing machine. When the door is closed and the machine switched on, an electric motor rotates the drum and washing.

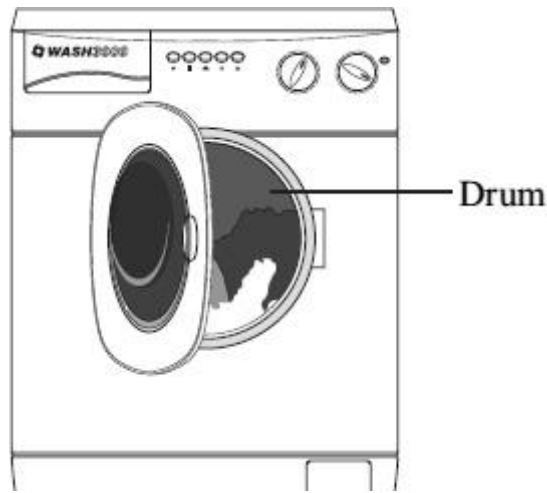

(a) What happens to the energy wasted by the electric motor?



---



---

(1)

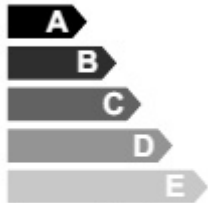
(b) The diagram shows the label from the new washing machine.

<b>Model – Wash 3000</b>	
<b>Energy A</b>	
More efficient  Less efficient	
Energy consumption kWh/wash cycle (based on 40 °C wash)	1.1

An 'A' rated washing machine is *more energy efficient* than a 'C' rated washing machine.

Explain what being *more energy efficient* means.

---



---



---



---

(2)

(c) The graph shows that washing clothes at a lower temperature uses less energy than washing them at a higher temperature. Using less energy will save money.

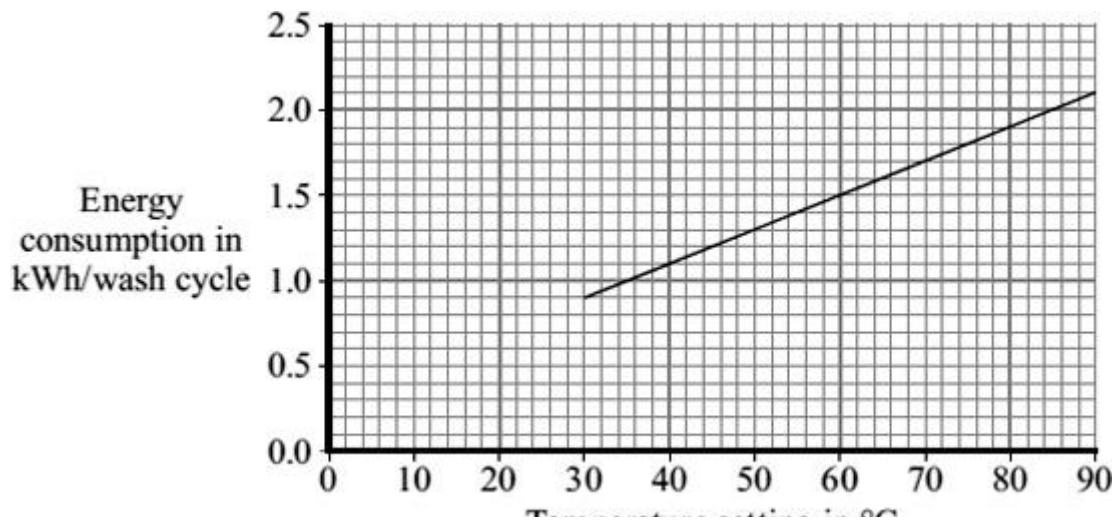

- (i) Electricity costs 12 p per kilowatt-hour (kWh).  
The temperature setting is turned down from 40 °C to 30 °C.

Use the graph and equation in the box to calculate the money saved each wash cycle.

$\text{total cost} = \text{number of kilowatt-hours} \times \text{cost per kilowatt-hour}$
--------------------------------------------------------------------------------------------

Show clearly how you work out your answer.

---



---

Money saved = \_\_\_\_\_ p

(2)

- (ii) Suggest why reducing the amount of energy used by washing machines could reduce the amount of carbon dioxide emitted into the atmosphere.

---



---

(1)

(Total 6 marks)

**Q3.**

A homeowner has installed electric underfloor heating in the kitchen. When the heating is switched on, an electric current flows through wires running under the tiled floor surface.

- (a) What is an electric current?

---

(1)

- (b) The graph shows how the power output of an underfloor heating system depends on the area of the floor that is heated.

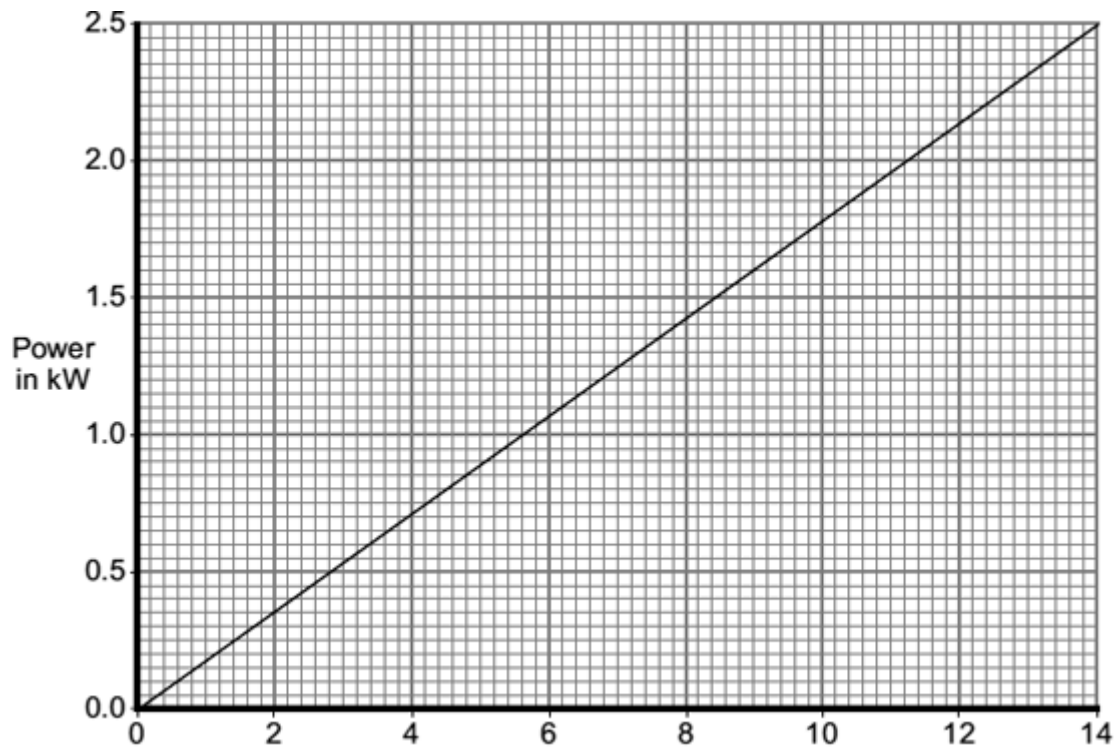

The area of the homeowner's kitchen floor is  $9.0 \text{ m}^2$ .

Calculate, using the graph, the current drawn from the 230 V mains supply by the heating system.

Show clearly how you work out your answer and give the unit.

---



---



---



---

Current = \_\_\_\_\_

(4)  
(Total 5 marks)