

Name of the Student: _____

Max. Marks : 26 Marks

Time : 26 Minutes

Q1.

Figure 1 shows the design of a playground ride.

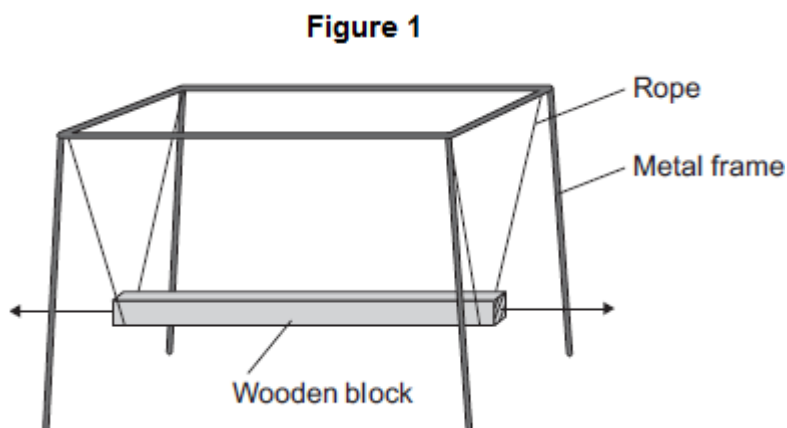

A large wooden block rests on ropes. The ropes are attached to a metal frame.

Children sit on the wooden block.

When the wooden block is moved to the left and released it moves to and fro.

When the wooden block returns to the point of release it has completed one cycle.

(a) Identify **two** possible hazards of the ride in **Figure 1**.

(2)

(b) The designer of the ride wants to know if the ride has the same time period as a pendulum of the same length.

The designer used a model of the ride and a pendulum as shown in **Figure 2**.

Figure 2

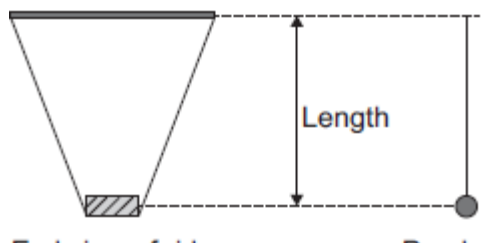

The designer measured the time taken to complete 10 cycles for different lengths of both the model ride and the pendulum.

The results for the model ride are shown in **Table 1**.

Table 1

| Length in metres | Time for 10 cycles in seconds | | | | Mean time period in seconds |
|------------------|-------------------------------|-------------|------------|------|-----------------------------|
| | First time | Second time | Third time | Mean | |
| 0.100 | 6.36 | 6.37 | 6.29 | 6.34 | 0.63 |
| 0.150 | 7.76 | 7.74 | 7.80 | | |
| 0.200 | 8.97 | 8.99 | 8.95 | 8.97 | 0.90 |

The results for the pendulum are shown in **Table 2**.

Table 2

| Length in metres | Time for 10 cycles in seconds | | | | Mean time period in seconds |
|------------------|-------------------------------|-------------|------------|-------|-----------------------------|
| | First time | Second time | Third time | Mean | |
| 0.250 | 10.00 | 10.04 | 10.02 | 10.02 | 1.00 |
| 0.300 | 10.99 | 11.01 | 10.94 | 10.98 | 1.10 |
| 0.350 | 11.88 | 11.83 | 11.87 | 11.86 | 1.19 |

- (i) Complete **Table 1**, giving values to an appropriate number of significant figures.

(3)

- (ii) The investigation already includes repeated readings.

Suggest **one** improvement that could be made to this investigation.

- (iii) The designer reads in an Advanced Physics textbook that:
'The square of the time period, T , for a simple pendulum is proportional to its length, l .'

$$T^2 \propto l$$

Would the model ride have the same time period as a simple pendulum of the same length?

Use **one** row of data from **Table 1** and **one** row of data from **Table 2** to work out your answer.

State your conclusion.

(3)

- (c) The ride was redesigned and built to make it safer.

The wood was moving at maximum speed. The maximum kinetic energy of the wood was 180 J.

A parent applied a force to the wood and stopped it in a distance of 0.25 m.

Calculate the force required.

Force = _____ N

(3)

(Total 12 marks)

Q2.

The image below shows a solar thermal power station that has been built in a hot desert.

The power station uses energy from the Sun to heat water to generate electricity.

Energy from the Sun is reflected towards a solar receiver using many mirrors.

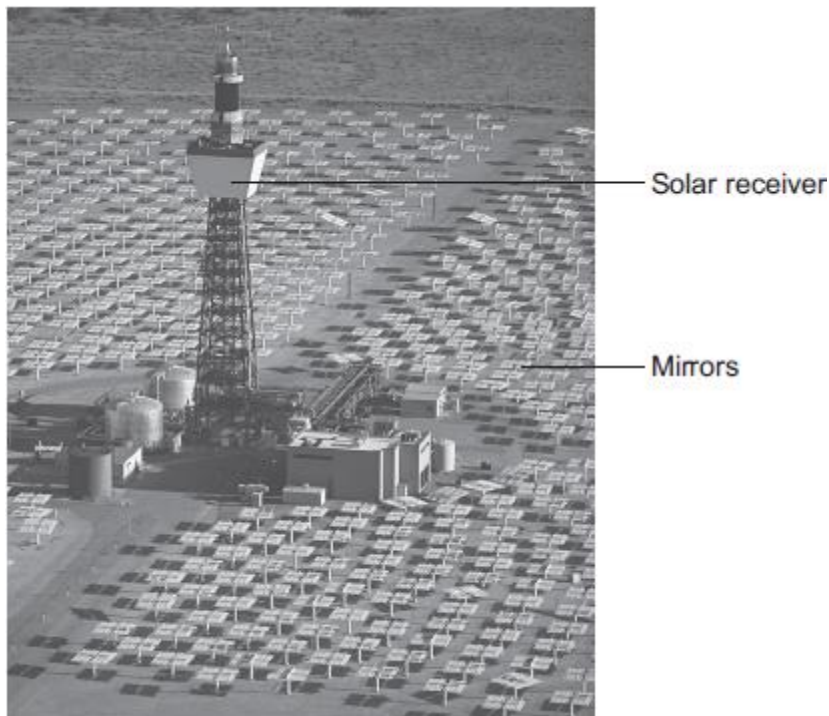

© Kim Steele/Photodisc/Thinkstock

- (a) (i) Which part of the electromagnetic spectrum provides most of the energy to heat the water in a solar thermal power station?

(1)

- (ii) Describe how heated water is used to generate electricity by this solar thermal power station.
The process is the same as in a fossil fuel power station.

(3)

- (b) A new type of solar power station, called a solar storage power station, is able to store energy from the Sun by heating molten chemical salts.
The stored energy can be used to generate electricity at night.

- (i) It is important that the molten chemical salts have a high specific heat capacity. Suggest **one** reason why.

(1)

- (ii) The solar storage power station can store a maximum of 2 200 000 kWh of energy.
The solar storage power station can supply a town with a maximum electrical power of 140 000 kW.

Calculate for how many hours the energy stored by the solar storage power station can supply the town with electrical power.

Give your answer to 2 significant figures.

Time = _____ hours

(3)

- (iii) **Table 1** gives information about the place where the solar storage power station has been built.

Table 1

| Season | Mean number of daylight hours | Mean power received from the Sun per square metre in kW |
|--------|-------------------------------|---|
| Spring | 11.5 | 0.90 |
| Summer | 13.5 | 1.10 |
| Autumn | 12.0 | 0.95 |
| Winter | 10.5 | 0.71 |

The solar storage power station does not operate at the maximum possible electrical output every day of the year.

Suggest why.

(2)

- (c) Power stations do not work at maximum possible electrical output all the time. The 'capacity factor' of a power station is calculated using the equation:

$$\text{Capacity factor} = \frac{\text{actual electrical output per year}}{\text{maximum possible electrical output per year}}$$

Table 2 shows capacity factors for different types of power station.

Table 2

| Type of power station | Renewable energy source | Capacity factor |
|-----------------------|-------------------------|-----------------|
| Coal | No | 0.41 |
| Natural gas | No | 0.48 |
| Nuclear | No | 0.66 |
| Solar thermal | Yes | 0.33 |
| Tidal | Yes | 0.26 |
| Wind turbine | Yes | 0.30 |

- (i) Compare the capacity factors of the renewable power stations with those of the non-renewable power stations in **Table 2**. Explain the reason for the difference between the capacity factors.

(3)

- (ii) The capacity factor of a solar storage power station is higher than for all other renewable power stations. Suggest **one** reason why.

(1)

(Total 14 marks)