

Name of the Student: _____

Max. Marks : 20 Marks

Time : 20 Minutes

Q1.

- (a) Complete the following sentences.

Ultrasound waves have a minimum frequency

of _____ hertz.

The wavelength of an X-ray is about the same as

the diameter of _____ .

(2)

- (b) **In this question you will be assessed on using good English, organising information clearly and using specialist terms where appropriate.**

The images show one medical use of ultrasound and one medical use of X-rays.



©monkeybusinessimages/iStock/Thinkstock



© targovecom/iStock/Thinkstock

Compare the medical uses of ultrasound and X-rays.

Your answer should include the risks, if any, and precautions, if any, associated with the use of ultrasound and X-rays.

(6)
(Total 8 marks)

Q2.

All objects emit and absorb infrared radiation.

(a) Use the correct answer from the box to complete each sentence.

| | | | |
|------------------|-------------------|-------------------|--------------------|
| dark matt | dark shiny | light matt | light shiny |
|------------------|-------------------|-------------------|--------------------|

The best emitters of infrared radiation have
_____ surfaces.

The worst emitters of infrared radiation have
_____ surfaces.

(2)

(b) **Diagram 1** shows a sphere which is at a much higher temperature than its surroundings.

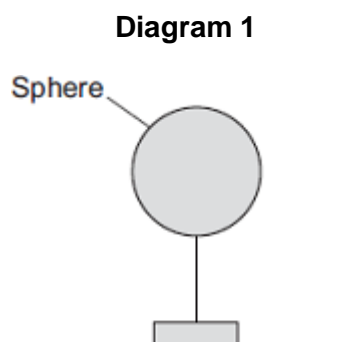

Energy is transferred from the sphere to the surroundings.

The table shows readings for the sphere in three different conditions, **A**, **B** and **C**.

| Condition | Temperature of sphere in °C | Temperature of surroundings in °C |
|------------------|------------------------------------|--|
| A | 70 | 5 |
| B | 80 | 0 |
| C | 90 | 30 |

In each of the conditions, **A**, **B** and **C**, the sphere transfers energy to the surroundings at a different rate.

Put conditions **A**, **B** and **C** in the correct order.

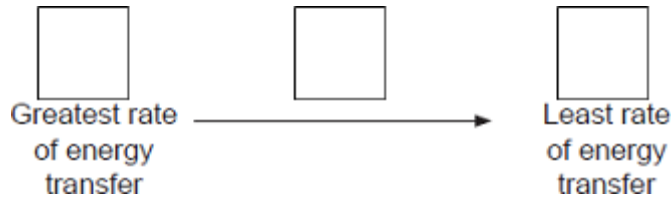

Give a reason for your answer.

(2)

(c) **Diagram 2** shows a can containing water.

A student investigates how quickly a can of water heats up when it is cooler than room temperature.

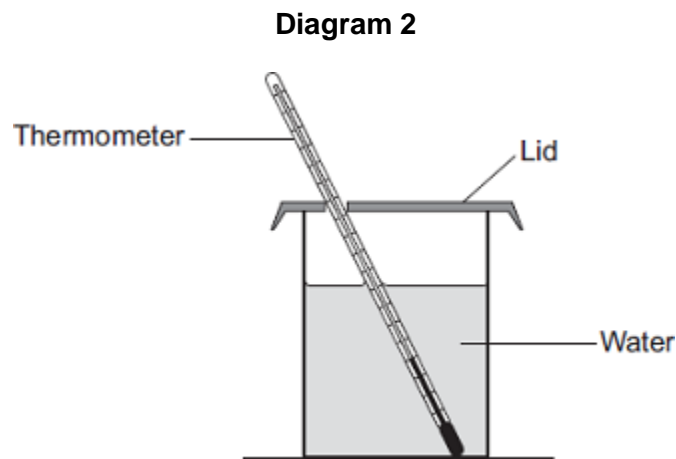

The student has four cans, each made of the same material, with the following outer surfaces.

dark matt dark shiny light matt light shiny

The student times how long it takes the water in each can to reach room temperature.

Each can contains the same mass of water at the same starting temperature.

(i) Which can of water will reach room temperature the quickest?

Give a reason for your answer.

(ii) Apart from material of the can, mass of water and starting temperature, suggest **three** control variables for the student's investigation.

- 1. _____

- 2. _____

- 3. _____

(3)

(d) The photographs show two different foxes.

Fox A



By Algalv (Own work) [CC-BY-3.0],
via Wikimedia Commons

Fox B



© EcoPic/iStock

Which fox is better adapted to survive cold conditions?

Give reasons for your answer.

(3)

(Total 12 marks)