

Name of the Student: _____

Max. Marks : 21 Marks

Time : 21 Minutes

Q1.

A student investigates magnetism using two toys as shown in Figure 7.

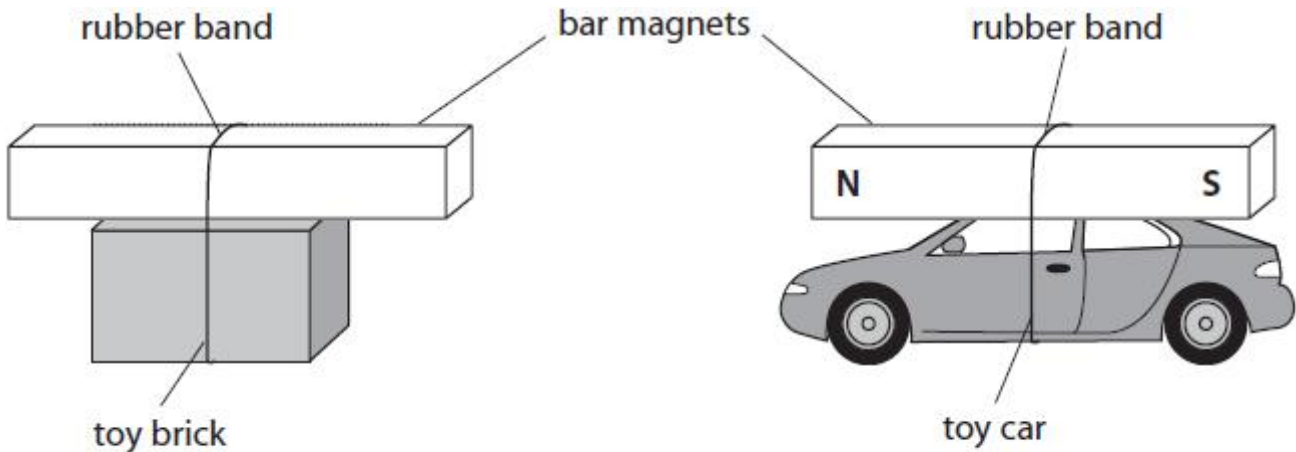

Figure 7

(i) There is a magnet attached to the top of each toy.

The student moves the toy brick towards the toy car.

The magnet on the toy brick repels the magnet on the toy car.

On Figure 7, label the north pole and the south pole on the magnet attached to the toy brick.

(1)

(ii) Explain why the toy car starts to move only when the toy brick gets near to the toy car.

(2)

.....
.....
.....
.....

(iii) The student thinks that two magnets on top of each other will produce a magnetic field that is stronger than the magnetic field from a single magnet.

The student has a metre rule and more magnets available.

Describe how the student could develop this investigation to test this theory.

(4)

.....

.....

.....

.....

.....

.....

.....

.....

(Total for question = 7 marks)

Q2.

A student's mobile phone has an app to measure a magnetic field.
 The student places the phone on a table and rotates the phone until it is pointing north.
 There are no magnets near to the phone.
 Figure 3 shows the display on the screen of the phone.

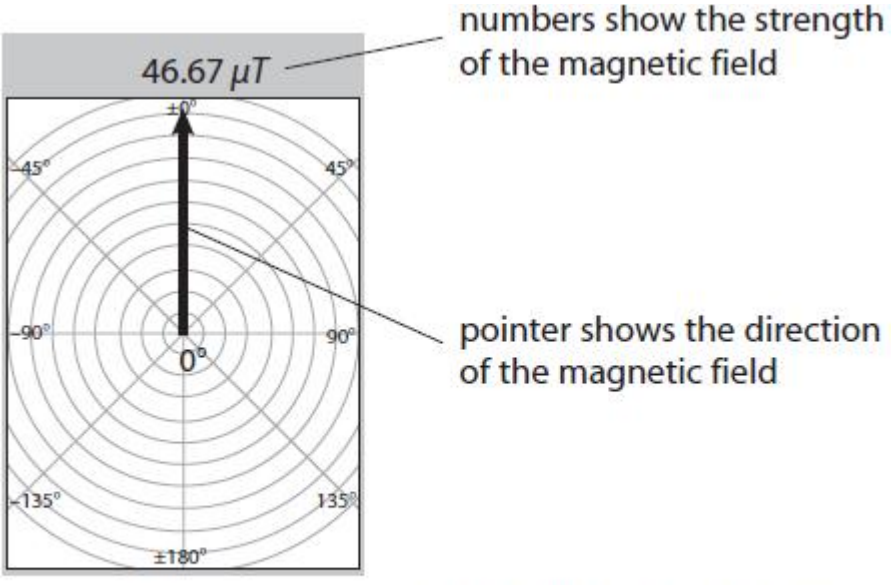

(Source: adapted from MGS Lite app for iPhone)

Figure 3

(i) State why the strength of the magnetic field shown is not zero.

(1)

.....

.....

The student places a magnet near to the phone on the table.

Figure 4 shows the magnet and the new display on the screen.

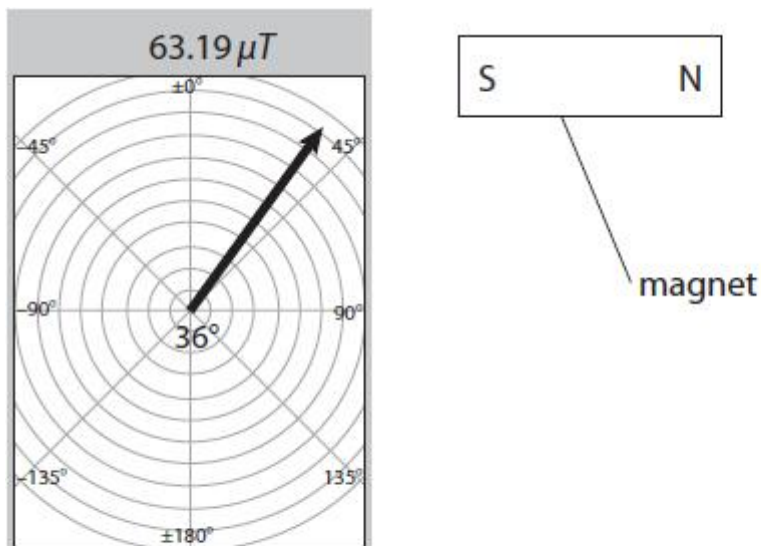

(Source: adapted from MGS Lite app for iPhone)

Figure 4

(ii) State **two** changes in the magnetic field measured by the phone from Figure 3 to Figure 4.

(2)

1

.....

2

.....

(iii) Describe how the student could use the mobile phone to investigate the strength of the magnetic field at different distances from the magnet.

(3)

.....
.....
.....
.....
.....
.....

(Total for question = 6 marks)

Q3.

Figure 1 shows a magnet, P, hanging from a support.

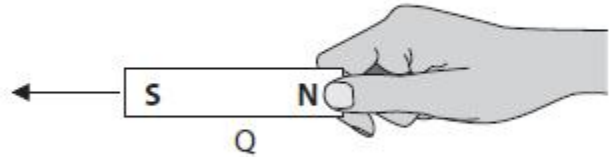
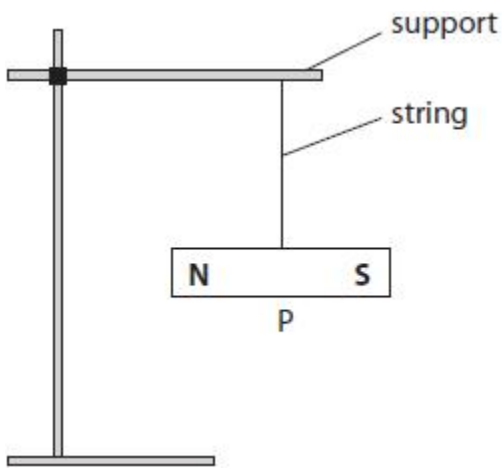

Figure 1

Explain what happens to magnet P when another magnet, Q, is brought towards it as shown.

(2)

.....

.....

.....

.....

(Total for question = 2 marks)

Q4.

A student has

- a power pack
- a long piece of wire
- a stiff card
- iron filings

Describe how the student could use this equipment to show the shape of the magnetic field produced by a current in the wire.

You may draw a diagram to help with your answer.

(4)

.....

.....

.....
.....
.....
.....
.....
.....

(Total for question = 4 marks)

Q5.

Figure 4 shows a wire passing through a piece of card.
The wire carries an electric current.

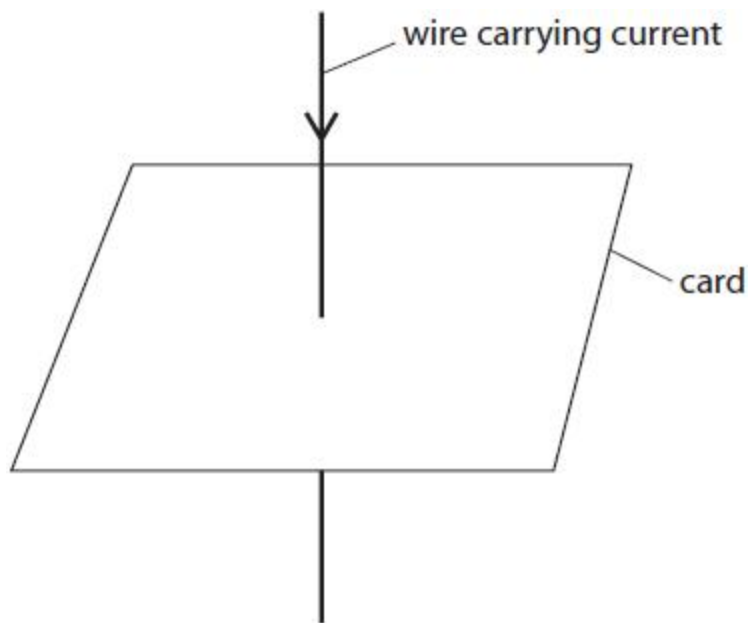

Figure 4

- (i) Draw **one** magnetic field line on Figure 4, to show the shape of the magnetic field produced by the current. (1)
- (ii) Draw **one** arrow on the field line you have drawn to show the direction of the magnetic field. (1)

(Total for question = 2 marks)